

PUBLIC MEMO – August 2, 2022

Subject: National Building Code Change – Stair Run

In 2021 the Province of New Brunswick enacted the *Building Code Administration Act*, which made the 2015 National Building Code of Canada (2015 NBC) mandatory, as of January 1, 2022.

As with all new versions of the Codes, some provisions are added, deleted, or changed. Important changes were made in 2015 NBC with respect to stairs, one of which is related to stair run, subject to article 9.8.4.2. of Division B.

Stair run is defined as “the horizontal distance between two adjacent tread nosings on a stair”.

See the illustration below from the 2015 NBC.

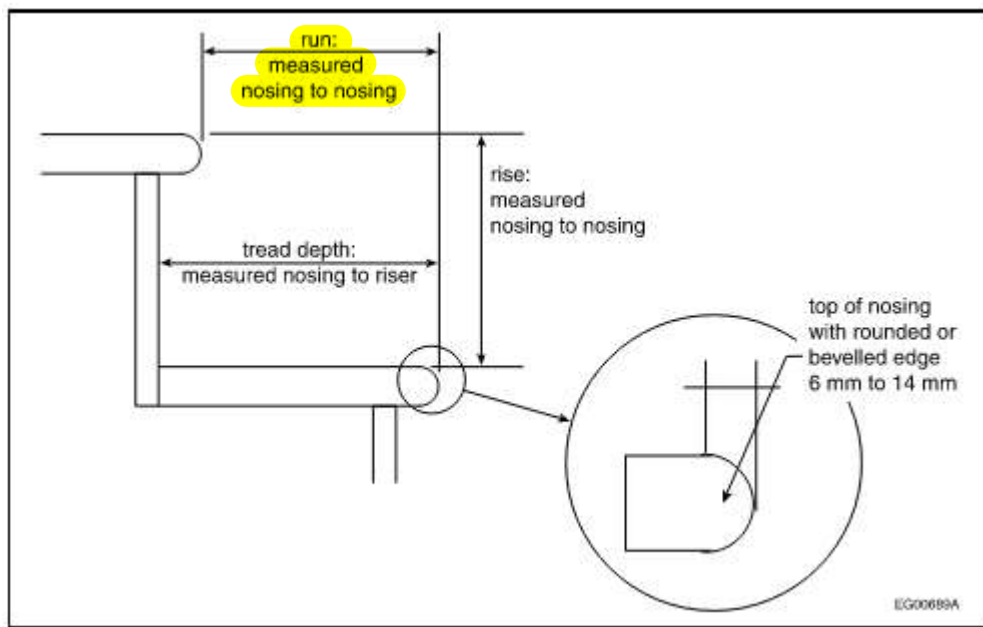

A significant change was made in Article 9.8.4.2. to **private stairs**, defined as *exterior and interior stairs that serve single unit dwellings, houses with secondary suite including their common spaces* (including garages that serve them).

Article 9.8.4.2. requires the run of **private stairs** to be a

- **Minimum of 255 mm** or 10" (formerly 210 mm or 8-1/4" inches in the former 2010 NBC), and
- **Maximum of 355 mm** or 14" (this has not changed).

Important

It has been brought to our attention that the increase in minimum stair run may be causing issues in procuring stair treads from providers (stores, manufacturers, etc.), that are able to meet this requirement. **Many stair tread being sold in stores or produced are 266 mm (10-1/2") or less in depth.**

This means that a typical 25mm (1") tread/nosing overhang (common practice in private stairs) would reduce the run to less than the minimum 255 mm required by the 2015 NBC, causing a Code violation.

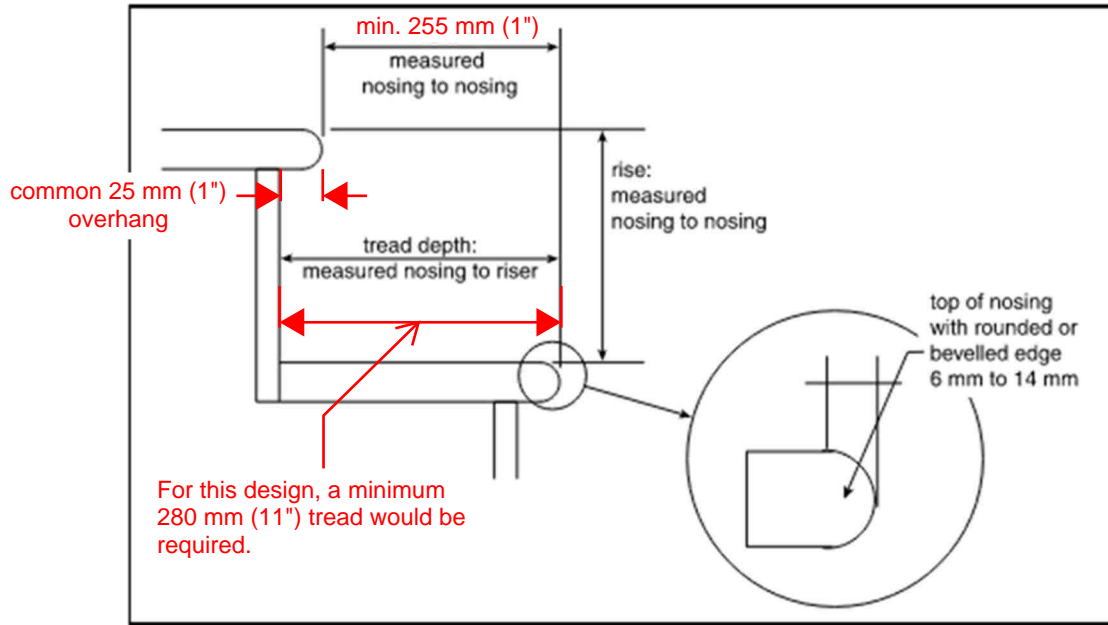

Before purchasing stair treads for your stairs, please ensure that they will be of sufficient depth to comply with the new 2015 NBC requirements mentioned above.

For stairs to have a 25 mm (1") tread/nosing overhang and comply the 255 mm (10") run required by article 9.8.4.2., the depth of a tread would need to be no less than 280 mm (11").

Please note that a tread overhang is not a requirement of the 2015 NBC for private stairs. As stated in article 9.8.4.2., the depth of a tread shall be "*not less than its run and not more than its run plus 25 mm*". However, common practice is to overhang the tread.

During inspection, this is an item that may be verified. If not in compliance, you can be required to correct the issue, which may be costly if it involves re-constructing the stair.

To view the 2015 National Building Code of Canada and access Code change information, please go to: <https://nrc-publications.canada.ca/eng/home/> and search **NRCCode**.

For questions related to this memo, you may contact our office using the information in the top right corner of page 1.

For specific questions or complaints related to this Code change and other Code changes please contact Codes Canada by telephone at 613-993-9960 or via email at codes@nrc-cnrc.gc.ca.

Memo provided by:
Greater Miramichi Regional Services Commission – Building Inspection Services